



A TEREX BRAND

PRODUCT SPECIFICATION

# 6400T

HORIZONTAL GRINDER/  
CHIPPER



WHOLE TREES • STORM DEBRIS • SLASH • STUMPS • REGRIND

# KEY FEATURES...

The CBI 6400 is a heavy-duty machine engineered for resiliency when grinding contaminated demolition debris, whole trees, storm debris, slash, and stumps. Manufactured with the most durable components available, this grinder thrives when processing high amounts of tough material. Four interchangeable rotors give this horizontal grinder the versatility needed for today's changing markets. The grinding chamber rises, providing full access for ease of maintenance.

Operators can transform this whole tree grinder into a machine built for grinding contaminated demolition debris just by swapping the rotor and screen(s). The rotor options available with this horizontal grinder are as rugged as they come. The solid steel rotor, with (20) 152 mm x 203 mm striker plates, is ideal for grinding contaminated railroad ties, municipal solid waste, and demolition debris. If you're in the market for forestry debris and mulch processing, the forged drum rotor with 101 mm hammers and reversible tips are your best option. Few machines have the ability to go into the woods and produce "port-quality" product; the 6400T gets it done.

The 6400T can also be converted to a whole tree chipper by installing a 2-pocket or 4-pocket chipper rotor. The 2-pocket rotor features two rows of knives for chip lengths of 19 mm to 32 mm for producing fuel chips from stemwood. The 4-pocket chipper rotor has four rows of knives for chip lengths of 2 mm to 12 mm. The four-pocket chipper rotor produces wood microchips from stemwood suitable as feed stock for producing wood pellets.

Customers can chip logs to various sized chips at rates up to 181 tons per hour thanks to its extensive power unit. It is powered by a CAT C27; 1050 HP engine. The 6400T is also equipped with a radiator featuring a Flexxair Auto-Reversible Fan for auto cleaning, a PT Tech hydraulic clutch with pump drive, and a CAT Air Filtering System.

## Four interchangeable rotors. Next-generation versatility.

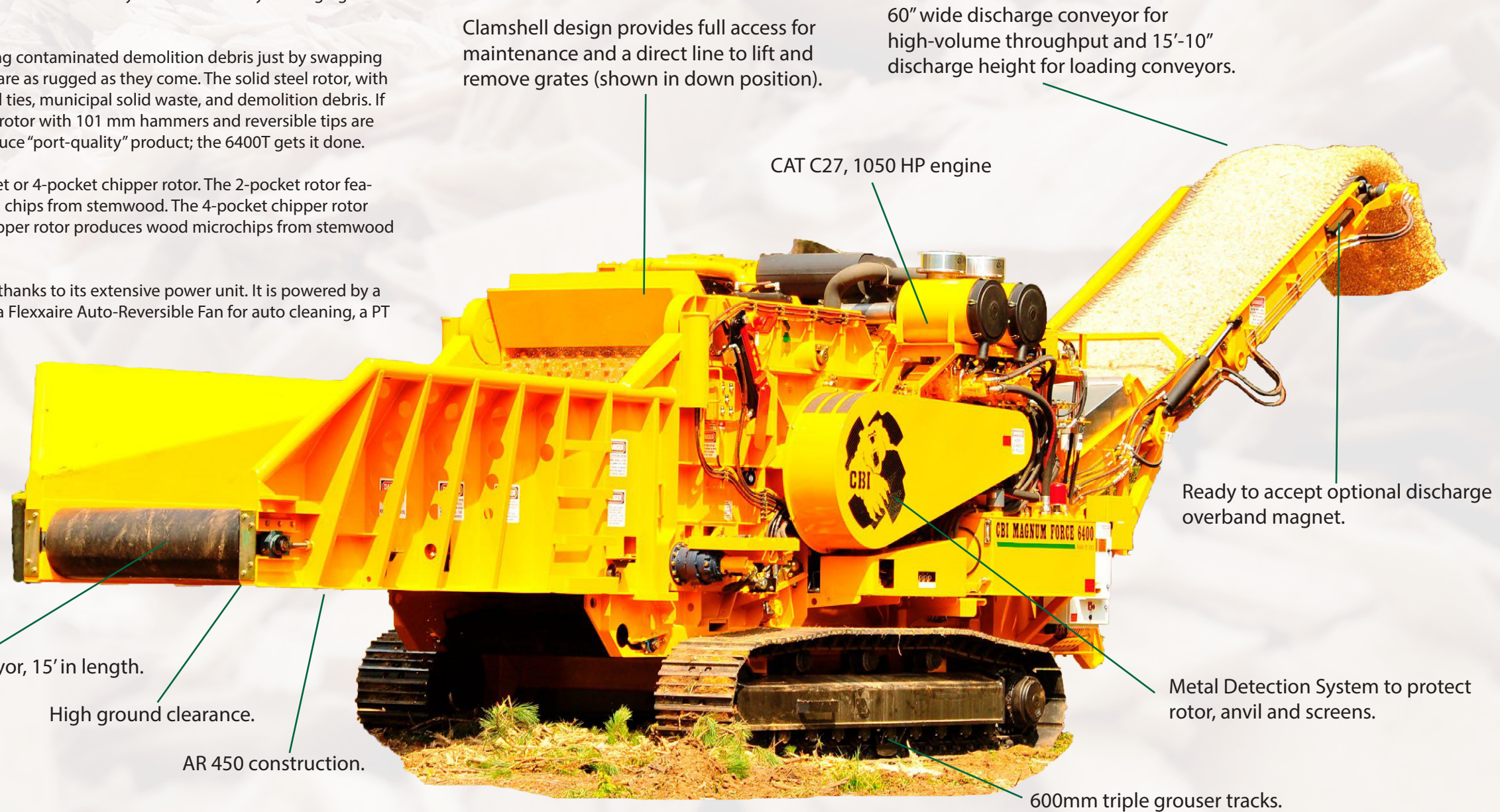

60" wide infeed conveyor, 15' in length.

High ground clearance.

AR 450 construction.

CAT C27, 1050 HP engine

60" wide discharge conveyor for high-volume throughput and 15'-10" discharge height for loading conveyors.

Ready to accept optional discharge overband magnet.

Metal Detection System to protect rotor, anvil and screens.

600mm triple grouser tracks.

**Steel Drum**  
Twenty 6" x 8" striker plates held in place by two 1-1/4" bolts, designed for contaminated demolition debris, railroad ties and MSW.

**Forged Drum**  
3" thick rotor with twenty or twenty-four weld on Replace-A-Face™ hammers with reversible tips for forestry debris and mulch manufacturing.

**2-Pocket Chipper**  
Two rows of knives for average chip lengths of 3/4" to 1-1/4" to produce fuel chips from stem wood.

**4-Pocket Chipper**  
Four rows of knives for short chip lengths of 1/8" to 1/2" to produce short chips from stem wood suitable for pelletizing or pulverized fuel.

### Demolition grinding setup



Steel drum rotor with twenty 6" x 8" steel striker plates held in place by two 1-1/4" bolts, designed for contaminated demolition debris, railroad ties, and MSW.

Steel 6" by 8" striker plates, edged with aggressive carbide, pulverize material and outlast with impressive durability, saving time and money. Striker plates pictured to the right.

### Striker plates



### Forged 40" x 60" downswing rotor



### Various hammer inserts



# METAL DETECTION SYSTEM



A problem for any industrial grinder has to do with tramp metal entering the hog box and causing significant damage, which leads to downtime. The Metal Detection System™ (MDS) engages within milliseconds whenever the grinder's rotor makes contact with tramp metal.

The rotor is monitored by an adjustable electronic sensor to alert the control system when tramp metal is detected. It will automatically stop the rotor, raise the top feed roller and reverse the infeed to allow the operator to find the tramp metal.

## TRANSPORT DIMENSIONS

Width: 10'-2" (3 m)  
 Height: 12'-0" (3.6 m)  
 Length: 40'-10" (12.4 m)  
 Weight: 83,000 - 90,000 lbs. (approx.)

## DISCHARGE CONVEYOR

Width: 60" (1.5 m)  
 Length: 37' (11.2 m)  
 Height: 15'-10" (4.8 m)  
 Discharge belt includes magnetic head pulley and chute

## INFEED

Width: 60" (1.5 m)  
 Height: 46" (1.1 m)  
 Conveyor: 15'-0" (4.5 m), heavy-duty belting

## ENGINE/DRIVE

Caterpillar C27; 1,050HP (787 kW)  
 Fuel capacity 450 gallons (1,703 L)  
 PT Tech HPTO15 clutch  
 12 groove, 8-V section Arimid belt

## FAN

Reversing pitch radiator fan that reverses airflow automatically

## CONTROLS

Parker IQAN™  
 Remote control operated

## HYDRAULICS

Hydrostatic  
 Hydraulic capacity 95 gallons (359 L)

## EQUIPMENT PROTECTION

Metal Detection System™ (MDS)

## TRACKS

D5 600 mm triple grouser

## HAMMERMILL

Diameter: 40" (1 m)  
 Width: 60" (1.5 m)  
 Shaft: 6" (0.15 m)  
 Top Feed Roll: 40" diameter x 60"

Specification subject to change without notice.

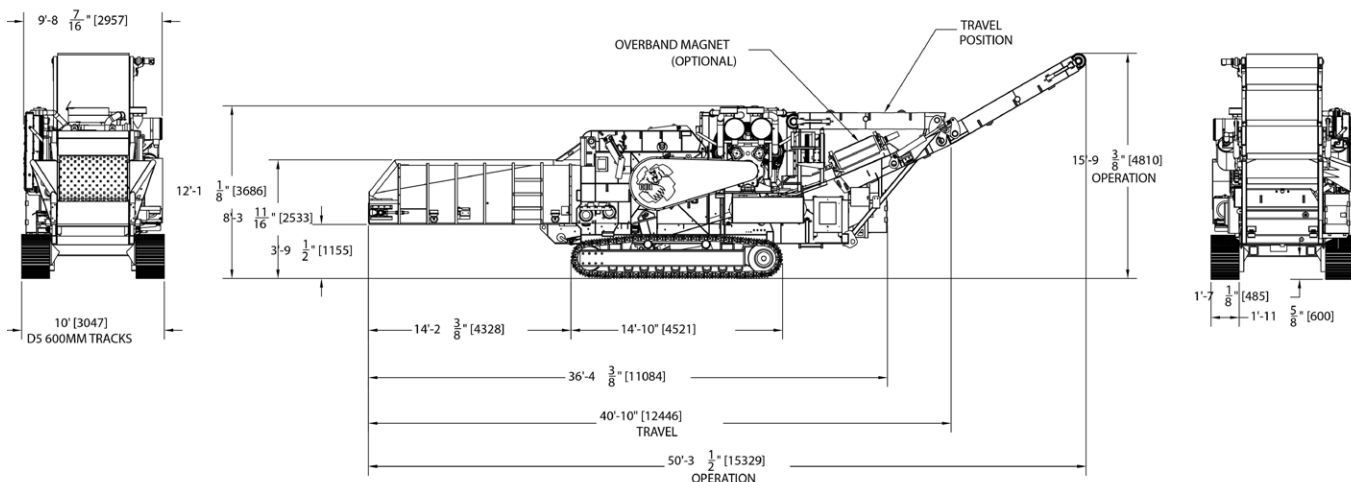

## Continental Biomass Industries

World's best stationary and portable material recovery systems.

22 Whittier Street, Newton, NH, 03858  
 Phone: (603) 382-0556 Fax: (603) 382-0557  
 Web: cbi-inc.com Email: info@cbi-inc.com

Distributed by: